

The logo for Aisle-Air Fans features the brand name in a bold, black, sans-serif font. A purple wavy line underlines the word 'Air'. Below this, the word 'FANS' is written in a smaller, black, sans-serif font.

Aisle-Air FANS

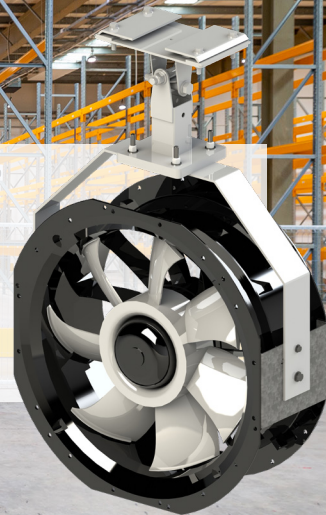

QUOTATION SUBMITTAL

EN300X3400 200-240V UNIT

Subject to Changes Without Notification.

ENVIRA-NORTH
SYSTEMS LIMITED

(519) 527-2198
enviranorth.com



AISLE-AIR FAN COMPONENTS DIAGRAM

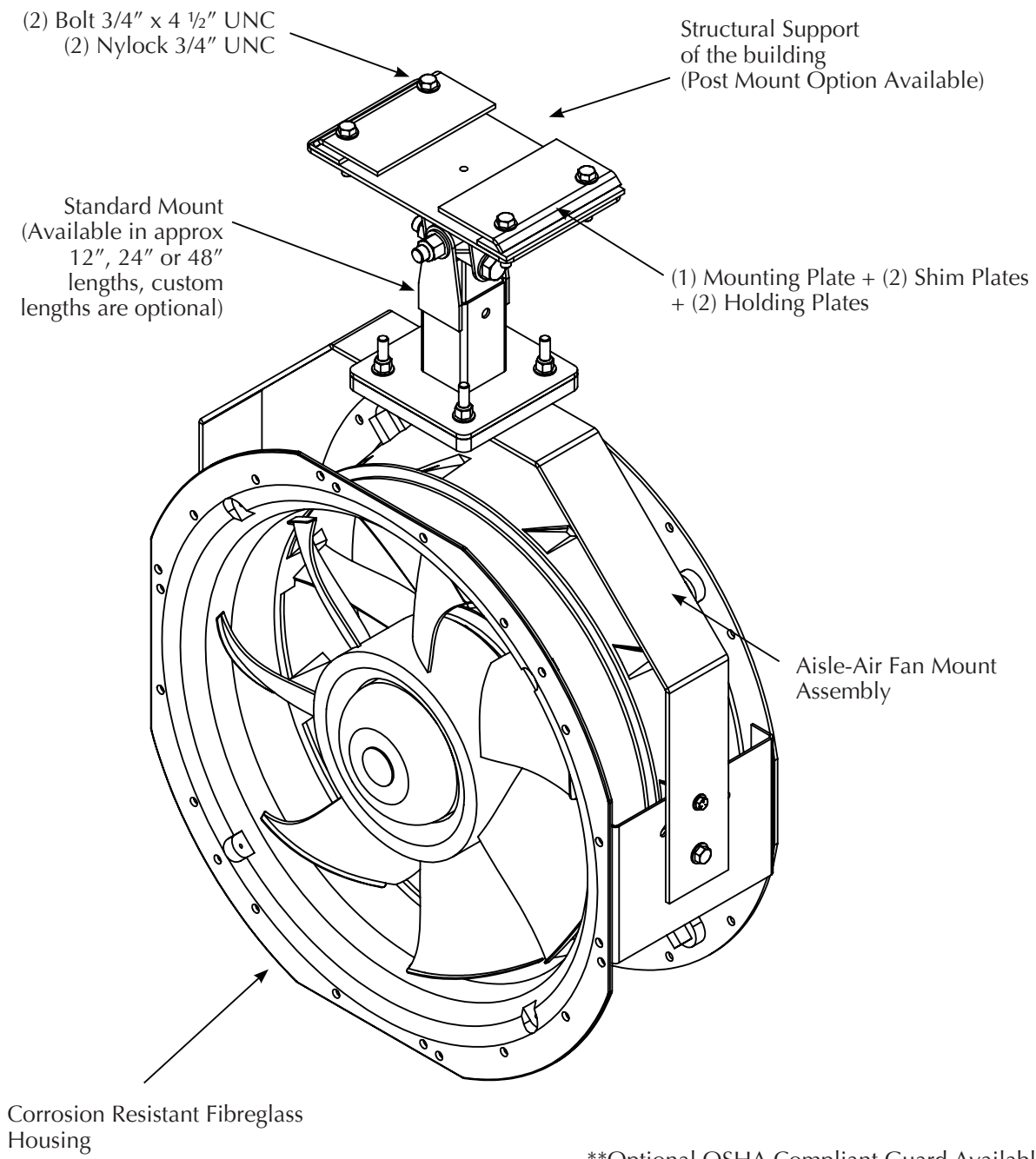

**Optional OSHA Compliant Guard Available

Note: All bolts are "Grade 5 UNO"
 FT = Fully Threaded
 (#) = Quantity Supplied

aisle-air fan spec drawing

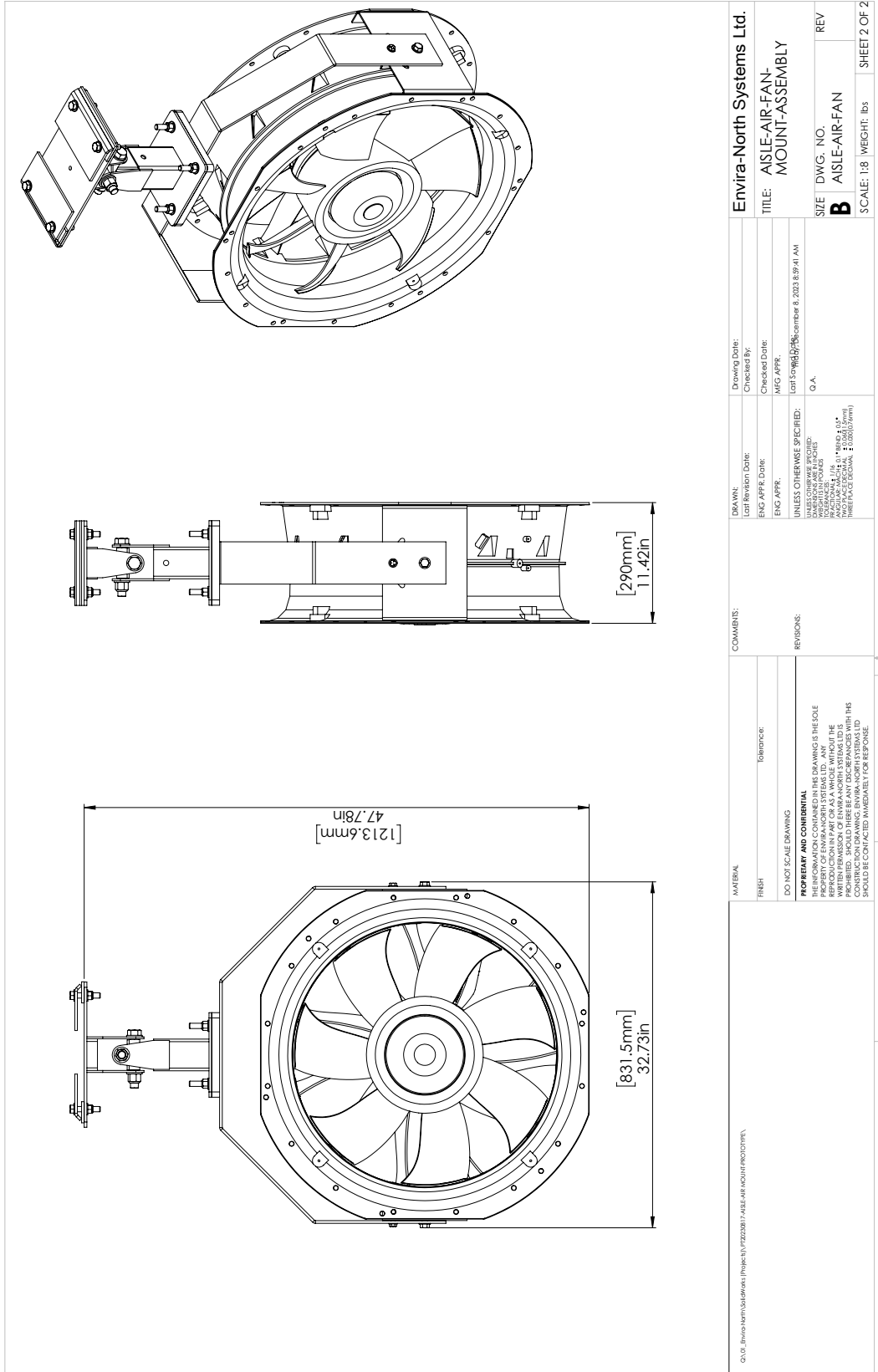

MATERIAL: FINISH:		COMMENTS: REVISIONS:		COMMENTS: REVISIONS:		DRAWN: [DATE]	DESIGN DATE: [DATE]	Envira-North Systems Ltd. TITLE: AISLE-AIR-FAN-MOUNT-ASSEMBLY
DO NOT SCALE DRAWING PROPERTY AND COPYRIGHT OF ENVIRA-NORTH SYSTEMS LTD. ANY REPRODUCTION OR TRANSMISSION OF THIS DRAWING WITHOUT THE WRITTEN PERMISSION OF ENVIRA-NORTH SYSTEMS LTD IS PROHIBITED. SHOULD THERE BE ANY DISCREPANCIES WITH THIS DRAWING, THE DRAWING SHALL PREVAIL AND THE CLIENT SHOULD BE CONTACTED IMMEDIATELY FOR RESPONSE.		UNLESS OTHERWISE SPECIFIED: IN THE FOLLOWING UNITS: DIMENSIONS IN MILLIMETERS OR INCHES UNLESS OTHERWISE SPECIFIED.		UNLESS OTHERWISE SPECIFIED: IN THE FOLLOWING UNITS: DIMENSIONS IN MILLIMETERS OR INCHES UNLESS OTHERWISE SPECIFIED.		ENG APPR: [DATE]	ENG APPR: [DATE]	SIZE: DWG. NO. B AISLE-AIR-FAN
Q.N.B. Envira-northsystems (Project) VITE2023B (AISLE-AIR-MOUNT-PROTOTYPE)		G.A.		G.A.		SCALE: 1:8 WEIGHT: lbs SHEET 2 OF 2		

AISLE-AIR FAN SPECIFICATIONS

General

Model Number.....	EN300X3400
Diameter.....	831.5 mm (32.73 in)
Controls.....	IP55, *Integrated Controls – MODBUS Signal
*Aisle-AIR Fan onboard controls require an HMI for operation	
Weight (no mount).....	56.7 kgs (125 lbs)
Packaged Fan (36" x 36" x 12").....	58.9 kgs (130 lbs**)
** Mounts, extensions & controls packages separately. Weights may vary.	

Performance

Maximum Velocity.....	17.78 m/s (3500 ft/min)
Air Speed.....	Up to 15 MPH
Maximum Speed.....	1600 RPM
Power Usage.....	360 W
Maximum Coverage.....	20 ft width x 100 ft length (6.1m x 30.5 m)

Construction

Fan Housing.....	Corrosion Resistant Fibreglass
Fan Mount Assembly.....	Corrosion Resistant Steel

Mounting Hardware

Standard Mount.....	Universal I-Beam Clamp w/ Swivel
Standard Drop.....	1 ft / 2 ft / 4 ft
Drop Extensions (Optional).....	1 ft / 2 ft / 4 ft

Mounting

Open Web Steel Joist (Optional).....	Steel Beam With Brackets
Wood Beam Mount (Optional).....	Steel Machined Mount Plates
Concrete Beam Mount (Optional).....	Steel Beam with Matching Mount Plates
Purlin "Z" Mount (Optional).....	Steel Beam Brackets
Steel Thickness Varies Depending on Beam Span.....	Consult Factory for Specifics

*Please see Altra-Air Installation Guide for more information regarding mounting hardware.

Direct Drive Motor

Size.....	360 kW
Volts.....	200 V - 240 V
Amps Consumed.....	6.9 A @ 240 V
Maximum Temperature.....	65°C (149°F)

Warranty

EN300X3400 Unit.....	3 Years
----------------------	---------



AISLE-AIR PACKAGING DETAILS

Packaged Fan

36" x 36" x 12" (91.44 cm x 91.44 cm x 30.48 cm)
130 lbs (58.9 kgs)

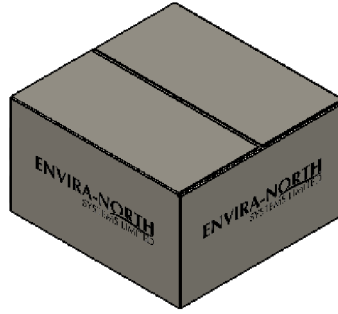

MOUNTS & EXTENSIONS PACKAGING DETAILS

These items can be placed inside the packaged fan when ordering with a fan. (Excluding 4 FT (1.22 M) items)
Please add the additional weight to the fan packages above.

1 FT (0.31 M) Packaged UMH Mount

9" x 9" x 15" (22.9 cm x 22.9 cm x 38.1 cm)
22 lbs (9.98 kgs)

2 FT (0.61 M) Packaged UMH Mount

9" x 9" x 28" (22.9 cm x 22.9 cm x 71.1 cm)
33 lbs (14.97 kgs)

4 FT (1.22 M) Packaged UMH Mount

9" x 9" x 51" (22.9 cm x 22.9 cm x 129.5 cm)
47 lbs (21.32 kgs)

2 FT (0.61 M) UMH Extension

9" x 9" x 28" (22.9 cm x 22.9 cm x 71.1cm)
21 lbs (9.53 kgs)

4 FT (1.22 M) UMH Extension

9" x 9" x 49" (22.9 cm x 22.9 cm x 124.5 cm)
31 lbs (14.06 kgs)

CONTROL OPTIONS

SmartAIR FAN CONTROL



- Automated Fan Control for Single or Multiple Fans
- Continually Measures Temperature and Humidity, Adjusting Fan Speed Accordingly
- Integrated Light Operation to Control On/Off
- Plug-and-Play Installation
- Monitor Performance of Motor and Drive

TouchAIR FAN CONTROL



- Single Point Fan Control
- Controls up to 20 Fans
- CAT-5 Daisy Chain Connections
- Intuitive Operation
- Individual and Group Controlling
- Remote Diagnostics
- Over 500m (1640') of Wire Distance
- Used in Conjunction with ZoneAIR Fan Control

Tel: 1-519-527-2198 Fax: 1-519-527-2560
Toll Free: 1-886-771-7766

bigair@enviranorth.com

139 Sparling St. P.O Box 668
Seaforth, Ontario
Canada N0K 1W0

enviranorth.com